

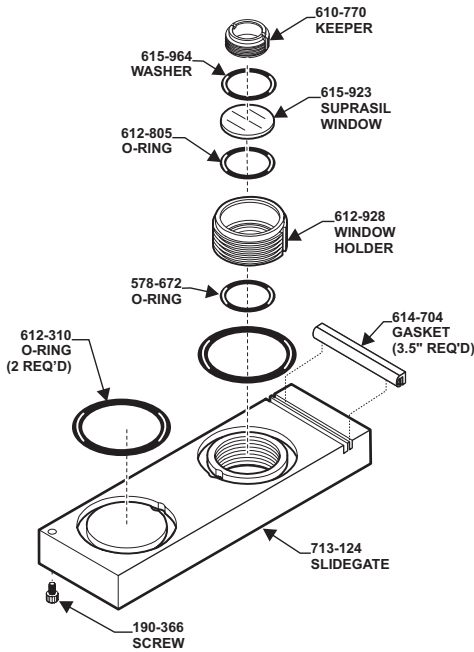

GDS-850A Consumable & Spares Reference

Note: Part numbers and standards' values may change. Consult LECO for the latest information.

	CATHODE	ANODE	SLEEVE	O-RING "A"	O-RING "B"	INNER SPACER
2 MM	616-999	612-823	607-399	607-315	534-356	618-296
4 MM	616-999	612-815	607-399	607-315	534-356	618-296
7 MM	612-825	612-826	607-506	607-314	607-314	607-618



713-121 SLIDE WINDOW ASSEMBLY
NOTE: For spectrometers with wavelengths <165 nm 612-807 (Suprasil) Window required.

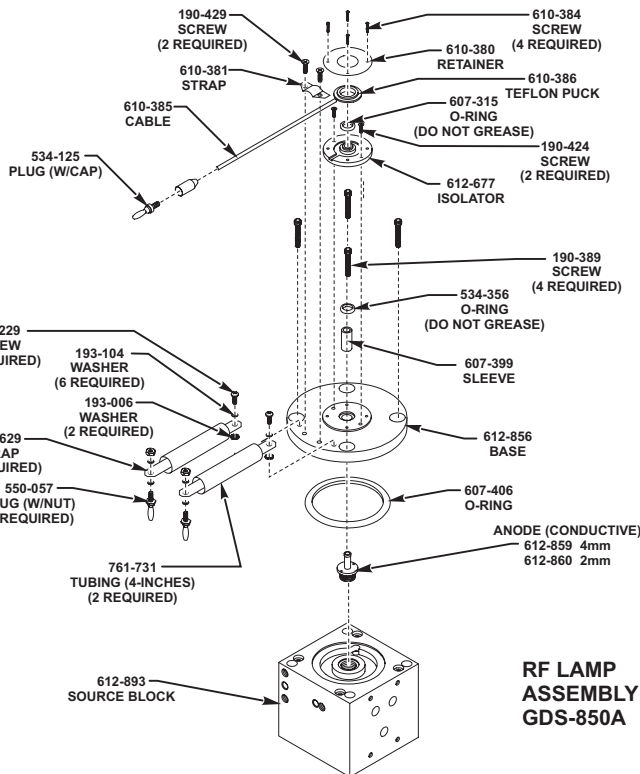
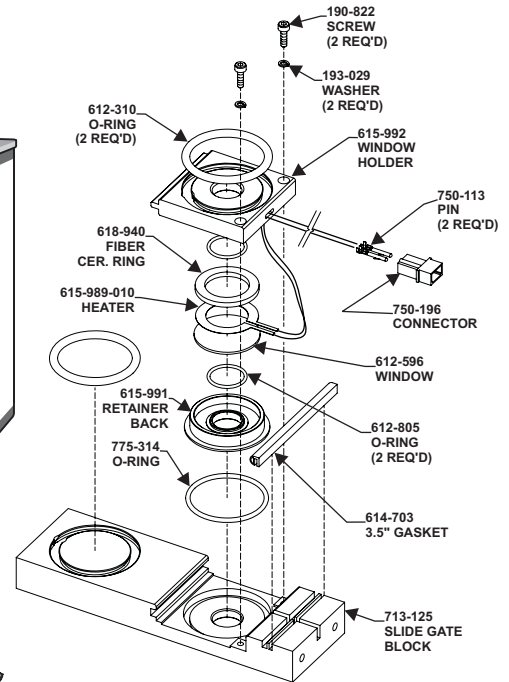
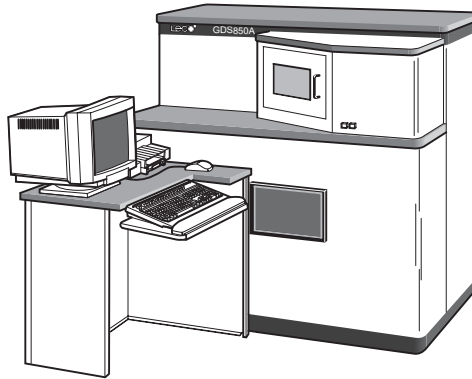

**RF LAMP ASSEMBLY
GDS-850A**

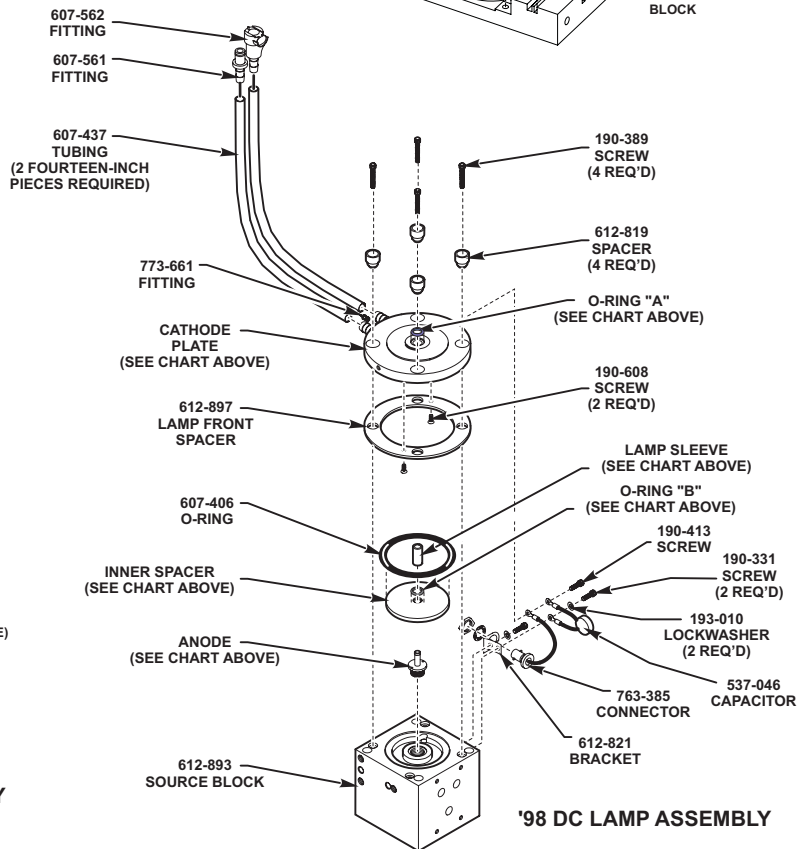

'98 DC LAMP ASSEMBLY

See reverse side for contact information

CONSUMABLES

502-237 Foam Wipes
534-356 Inner Sleeve O-ring (red)
607-073 Left Lens Block Door O-ring
607-302 Mist Oil Filter
607-303 Mist Odor Filter
607-401 Reamer Bit Assembly 4 mm
607-406 Ceramic Spacer O-ring (red)
607-623 Inner Lens Assembly O-ring
771-445 Cleaning Port O-ring
775-312 Lens Keeper to Lamp O-ring
779-377 Vacuum Pump Oil (400 ml)
910-000-105 Lens Cleaning Tissue
612-509 Fomblin Grease
203-913 Printer Paper, 5000 sheets
612-899 Drill Bit, 4 mm (soft metals)
615-923 Suprasil Window (*For wavelengths >165 nm*)
612-807 Mg/FI Window; '98 non-heated
(*wavelength < 165 nm*)
612-596 Mg/FI Window, heated

SPARES

615-961 Suprasil Window Insert Assembly, includes
(1) 610-770 Keeper, (1) 615-964 Washer,
(1) 615-923 Window, (1) 612-805 O-ring,
(1) 612-928 Holder
NOTE: (For wavelengths ≥ 165 nm)
607-766 Outer Lens Assembly, includes (1) 607-499 Outer
Lens Keeper, (1) 607-767 Outer Lens Body Holder,
(1) 615-966 Suprasil Lens

PRINTER CARTRIDGES

611-227 HP-600 Black
611-228 HP-600 Color
614-459 HP-700/800 Black
614-460 HP-700/800 Color
620-632 HP-950 Series Color
601-484 Printer Ribbon (Dot Matrix)

SLIDE WINDOW ASSEMBLY

612-928 Window Holder
612-805 O-ring
615-964 Teflon Washer
610-770 Keeper
578-672 O-ring Slidegate
615-923 Suprasil Window

TOOLS

617-274 Anode Alignment Tool/Sleeve Removal
612-399 Anode Depth Micrometer
612-799 Sleeve Removal Tool
612-811 Assy. Tool Window Holder
607-312 Magnetic Sample Holder

OPTIONS

612-933 Reamer - Soft Materials (4 mm Source)
612-708 Sample Holder, 2 mm, Wires
612-798 Sample Holder, 13 mm, Briquettes
612-774 Sample Holder, Porous Samples
612-775 Sample Holder, TRS Bar Holder
259-030 Least Cost Charge Software
259-012 Alloy ID Software
607-769 Reamer Assembly, 2 mm
612-917 Okidata 320 Serial Printer
618-391 2 mm Lamp Small (6 mm O-ring)

'98 LAMP

607-315 Outer Sleeve O-ring, blue
534-356 Inner Ring O-ring, red
618-296 Inner Spacer
618-297 Inner Spacer, 2 mm
607-406 Ceramic O-ring
607-399 Sleeve, 4 mm
612-815 Anode, 4 mm
612-823 Anode, 2 mm
612-819 Spacer
190-389 Screw (lamp bolt)
612-879 4 mm Lamp Rebuild ('98)

RF LAMP

702-069 Retainer Insert
702-070 RF Anode Retainer
702-071 Insert Anode, RF, 2 mm Boron
702-072 Insert Anode, RF, 4 mm Boron

KITS

612-879 4 mm '98 Lamp Rebuild Kit (DC Lamp)
612-878 2 mm '98 Lamp Rebuild Kit (DC Lamp)
612-923 2 mm RF '98 Lamp Rebuild Kit
612-891 4 mm RF '98 Lamp Rebuild Kit
702-071-110 2 mm '98 Non-conductive Anode Kit
702-072-110 4 mm '98 Non-conductive Anode Kit

*NOTE: Part numbers may change.
Consult LECO for latest information.*

United States:

Ph: 1-800-292-6141
Fax: 269-982-8977

Canada:

Ph: 1-800-268-0215
Fax: 905-564-6582

represented by:

Other Countries:

Ph: 269-983-5531
Fax: 269-983-3850